

# HT50 Portable Drill

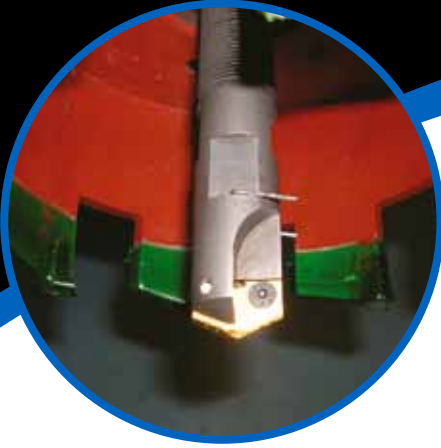

Integrated Solutions  
to Piping Problems



## **HT50 Portable Drill (16" stroke - 10" Capacity)**

**A versatile portable drilling and boring machine for general drilling and stud removal applications. The machine can be bolted directly to the work piece.**

- **Linear Rails & Guides - Accuracy and high load carrying capacity**
- **50 ISO Spindle accepts world wide standard up to 5 MT**
- **Helical geared spindle drive**
- **Optional auto feed gearbox and motor**

# HT50 Portable Drill



Integrated Solutions  
to Piping Problems

## RANGE

Maximum Hole diameter (through base)	125mm	5"
Standard stroke	405mm	16"
Maximum stroke available (optional)	800mm	31.5"
R.P.M – air 3.5hp or 5.0hp hydraulic	Min: 15	Max: 74
Drive – Pneumatic @ 6 bar (90 p.s.i)	3.5 Hp	1.11 Kw
Drive – Hydraulic @ 70 bar (1050 p.s.i)	5.0 Hp	3.73 Kw
Feed – Pneumatic @ 6 bar (90 p.s.i)	0.9 Hp	0.67 Kw
Feed – hydraulic @ 70 bar (1050 p.s.i)	2.2 Hp	1.64 Kw
Air consumption required	98 s.c.f.m	2.69 m3/m
Hydraulic supply required	40 L/min	8.8 gal/min

## FEED RATES

Variable auto feed (optional) 0 – 20 mm/min 0 - 0.75"/min  
Shipping weight 85 Kgs 187 lbs  
Machine weight (including 10kg auto feed) 60 kgs 132 lbs

## WEIGHTS AND DIMENSIONS

Shipping dimensions L - 110cm - (43") W- 40cm (16") H- 49cm (19")

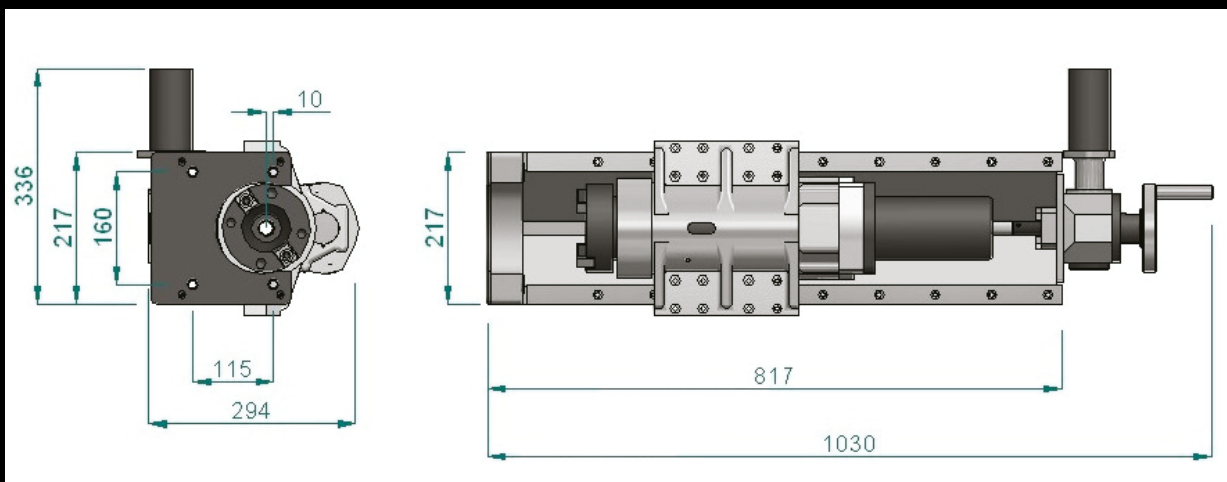

The machine is supplied complete with toolkit, air filter lubricator ( when air driven)  
and hose connection, storage / shipping box, CE certificate, Packing list and Manual