

Flange Facing AX1445

Technical documentation

AX1445

A lightweight, portable, flange facing, grooving and weld preparation machine full faced, raised face and grooved flanges from 355mm - 1140mm (14" - 45")

Typical Applications

- Lens Ring Seat Cutting and Polishing
- 'V' Groove Cutting
- Tube Sheet Machining

The Silk AX1445 is constructed, as the rest of the range, from the highest quality materials. It is designed to give machine shop accuracy, combined with ease of handling and portability in the flange range of 355mm (14") to 1140mm (45"). The machine consists of four main assemblies.

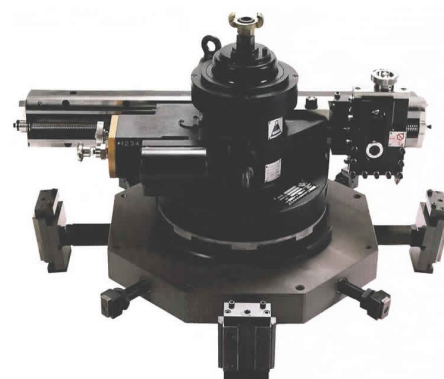

Base

The mounting bases for the machine are supplied in two sizes to ensure maximum stability throughout the machining range. The bases are set up using the clocking tower bare supplied, to centralise and level the base exactly. A base is adjusted parallel to the flange by four micro pads. It has a detachable locating spigot fitting into a hardened bush, ensuring the machine is positioned as accurately as the base is set.

Drive Hub

A 2.61kw (3.5hp) air motor is contained within the drive hub, giving plenty of power to tackle welds, bolt holes and more exotic materials such as stainless steels. The machine is surprisingly quiet as the exhaust is vented down the bore and muffled by its body.

Drive Gearbox

The versatility of this machine is a direct result of the use of the Silk four speed gearbox. This allows the machine to feed in or out to give a continuous spiral finish.

Adjustable Arm and Toolpost

Sliding in a dovetail clamp enables the surfacing arm to be positioned to suit the flange, or any obstructions around it. The arm is clamped on the dovetail and pressed down onto hardened pads to maintain accuracy. The swivel toolpost can be tilted for weld preparation, grooving or special applications.

Quality

All TEAM Engineering activities are conducted in strict conformance to the ISO9001 quality system.

Silk Design Department

All Silk machines are used by our on-site service technicians and over the years, we have modified and designed attachments to enable the Silk range of machine tools to undertake many specialist applications. Can we help you? Comprehensive CAD facilities operated by qualified design engineers and experienced project engineers are able to meet your exact requirements.

Integrated Solutions to Piping Problems | www.patriot-int.com

The Netherlands

Dordrecht

T: +31 (0) 78 652 41 11

E: info@patriot-int.com

United Kingdom

Aberdeen

T: +44 (0) 1224 724726

E: info@patriot-int.com

Belgium

Antwerp

T: +32 (0)36 00 17 07

E: info@patriot-int.com



Principal Dimensions	
Machine height	410mm (16 1/2")
Mounting base thickness	63.5mm (2 1/2")
Maximum rotational diameter	1150mm (45 1/4")
Minimum rotational diameter	800mm (31 1/2")
Toolpost travel	40 mm (1/18")
Weights	
Machine weight (less base)	105kg (231 1/2 lbs)
Nett weight (less wooden case)	227kg (500lbs)
Total shipping weight	300kg (660lbs)
Transportable case dimensions	
Length	1015mm (40")
Height	810mm (32")
Width	640mm (25")
General Information	
Depth of flange required to set base	130mm (5 1/8")
Machine height above flange face	345mm (13 3/4")
Final rotational speed	30rpm
Gripping range:	
Minimum recommended bore	355mm (14")
Maximum recommended bore	965mm (38")
Facing range:	
Minimum diameter	355mm (14")
Maximum diameter	965mm (38")
Drive motor:	2.61kw (3.5hp)
Minimum air supply requirements	6 bar 2.69m /min
	(90psi 95cfm)
Drive motor output	185rpm

Features

- Lightweight
- Quiet operation
- Machine shop accuracy
- Operates in any position
- Full toolkit and operators manual
- Pneumatic drive
- Fitted transportable case
- With kits supplied, will cut 'V' grooves, lens ring seats and other profiles

Integrated Solutions to Piping Problems | www.patriot-int.com

The Netherlands

Dordrecht

T: +31 (0) 78 652 41 11

E: info@patriot-int.com

United Kingdom

Aberdeen

T: +44 (0) 1224 724726

E: info@patriot-int.com

Belgium

Antwerp

T: +32 (0)36 00 17 07

E: info@patriot-int.com

