

V Groove Machining Kits

AXL012

Technical documentation

1. Remove standard saddle and replace with hand operated saddle ('D' section).

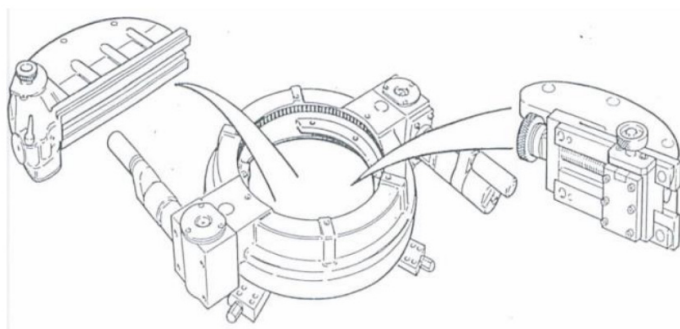

2. Using the standard tool holder, cut a vertical sided groove at the desired diameter. Remove cutting tool and by using a left/right handed plunge tool, remove sides of the grooves in a rough 'V' shape.

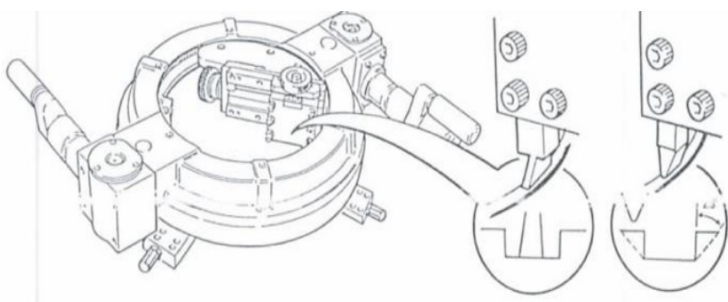

3. Remove the 'D' section saddle from the machine and replace standard toolpost with the 'V' groove toolpost. Refit the saddle on to the machine.

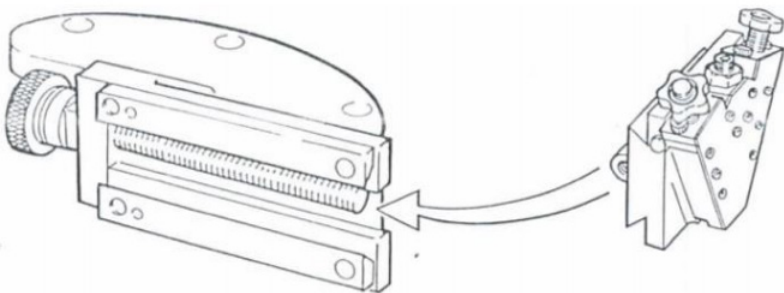

Integrated Solutions to Piping Problems | www.patriot-int.com

The Netherlands

Dordrecht

T: +31 (0) 78 652 41 11

E: info@patriot-int.com

United Kingdom

Aberdeen

T: +44 (0) 1224 724726

E: info@patriot-int.com

Belgium

Antwerp

T: +32 (0)36 00 17 07

E: info@patriot-int.com

- To set the toolslides on 'V' groove toolpost, slacken off the locknut and use an Allen key to adjust the pressure pads

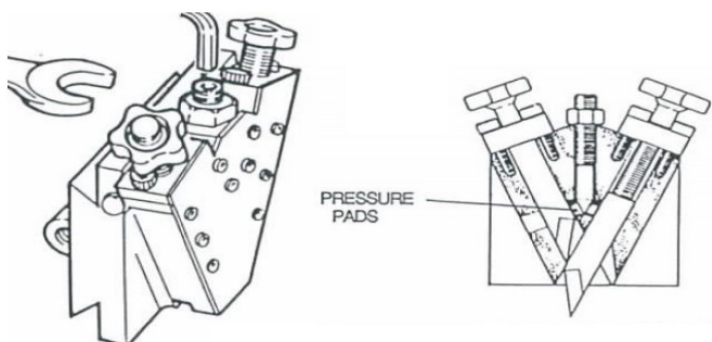

- Raise the unused slide by the appropriate thumbscrew. Lower the tool slide required, to gain access to the securing grub screws. Slacken off and attach the tool.

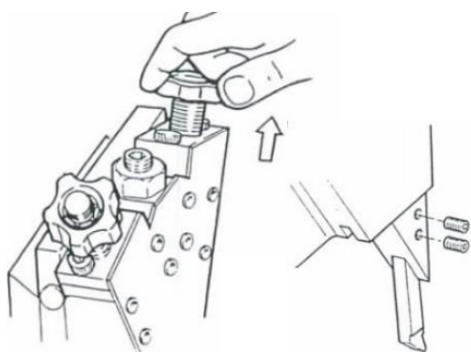

- Finally, hand finish the grooves by using the appropriate thumbscrew to lower the tool

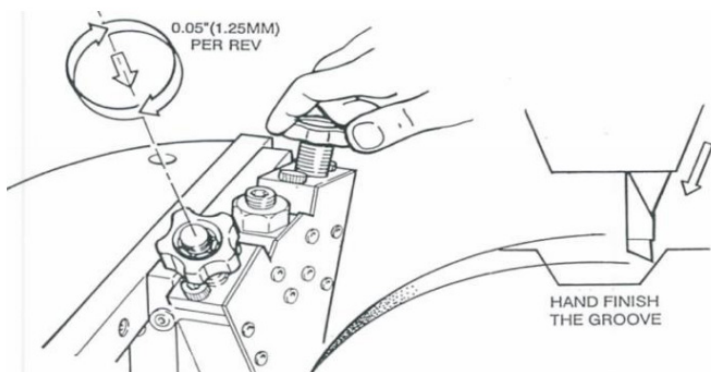

Integrated Solutions to Piping Problems | www.patriot-int.com

The Netherlands

Dordrecht

T: +31 (0) 78 652 41 11

E: info@patriot-int.com

United Kingdom

Aberdeen

T: +44 (0) 1224 724726

E: info@patriot-int.com

Belgium

Antwerp

T: +32 (0)36 00 17 07

E: info@patriot-int.com

